



Feature -

bi-color LED illuminated available
2P2T, 4P2T, lock / non-lock function

Application -

computer products
instrumentation
communication equipments

► **SPECIFICATIONS**

SWITCH SPECIFICATIONS	
POLE - POSITION	2P2T , 4P2T LOCK / NON-LOCK Action with LED
CONTACT RATING	30 V DC , 0.3 A
CONTACT RESISTANCE	20 mΩ MAX. 1.5 V DC ; 100 mA by Method of Voltage DROP
INSULATION RESISTANCE	100 MΩ MIN. 500 V DC
DIELECTRIC STRENGTH	Breakdown is not Allowable ; 500 V AC for 1 Minute
OPERATING FORCE	200 ± 100 gf
OPERATING LIFE	10,000 cycles
OPERATING TEMPERATURE RANGE	-20°C ~ 70°C
TOTAL TRAVEL	TRAVEL : 2.5 ± 0.3 mm TRAVEL : 3.3 ± 0.3 mm

LED SPECIFICATIONS						
ATTENTION  LEDs are Electrostatic Sensitive devices (+)○(+)○(-)	Unit	Value / LED Color				
		Blue	Green	Red	Yellow	
FORWARD CURRENT	If	mA	20	20	20	20
REVERSE VOLTAGE	Vr	V	5.0	5.0	5.0	5.0
REVERSE CURRENT	Ir	μA	10	10	10	10
FORWARD VOLTAGE@20mA	Vf	V	3.3-4.0	2.1-2.5	2.0-2.5	2.0-2.5
LUMINOUS INTENSITY@20mA	Iv	mcd	1300	700	900	700

■ Physical and electrical information of LED will be provided upon customer's request on switches .

► **HOW TO ORDER**

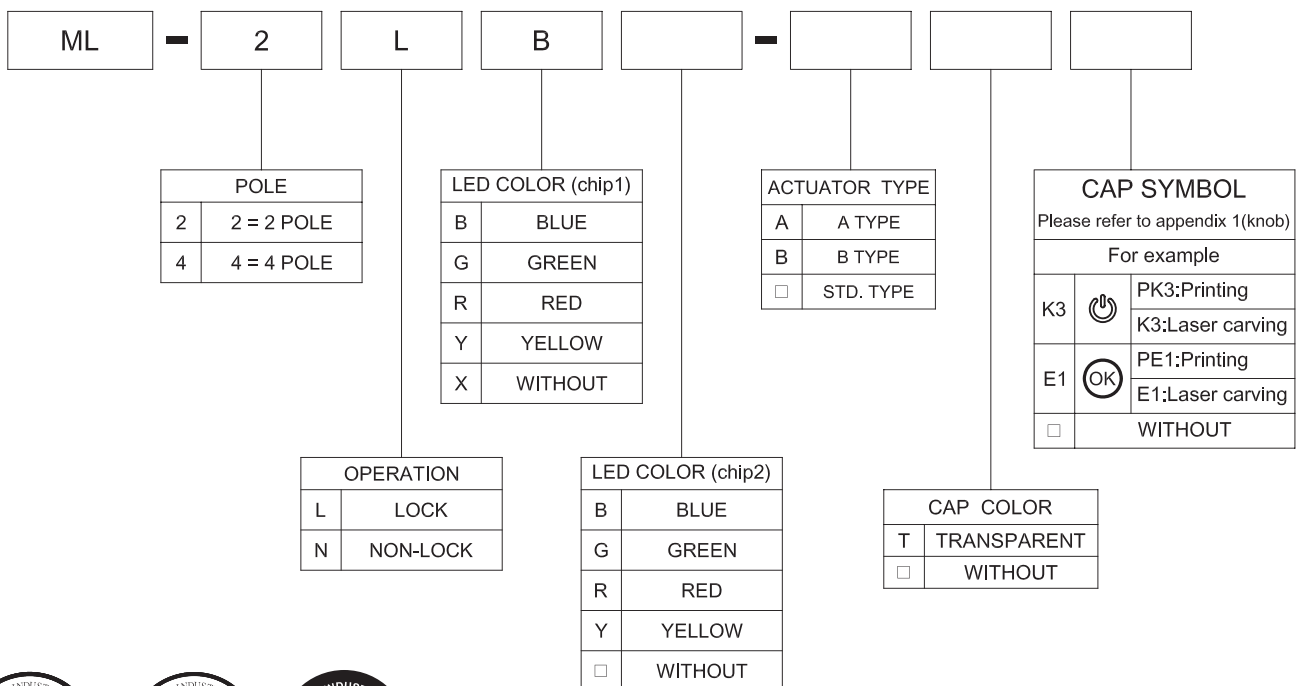

ML SERIES

LED PUSH BUTTON SWITCH

► DIMENSION

ML - 2 L □ □ - A

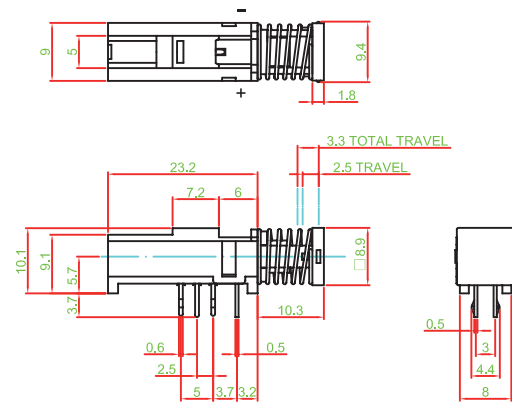

ML - 2 L □ □ - AT

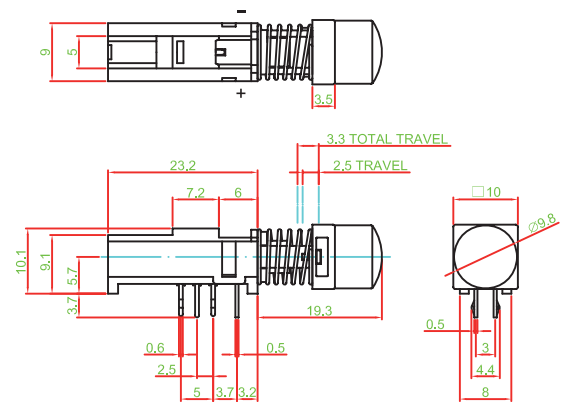

ML - 2 L □ □ - B

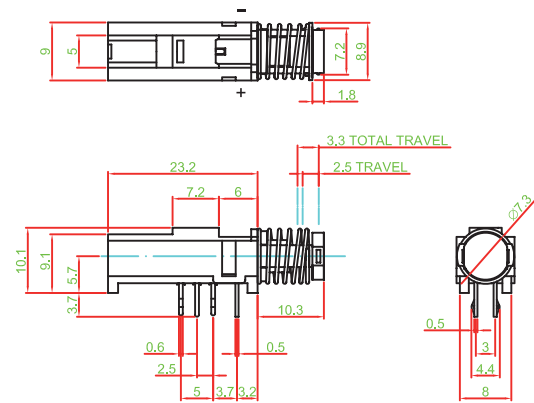

ML - 2 L □ □ - BT

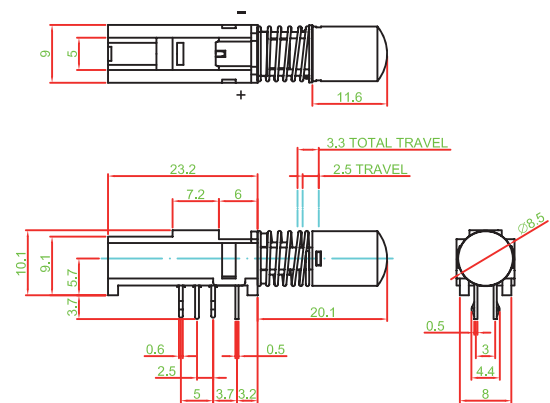

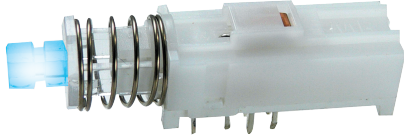
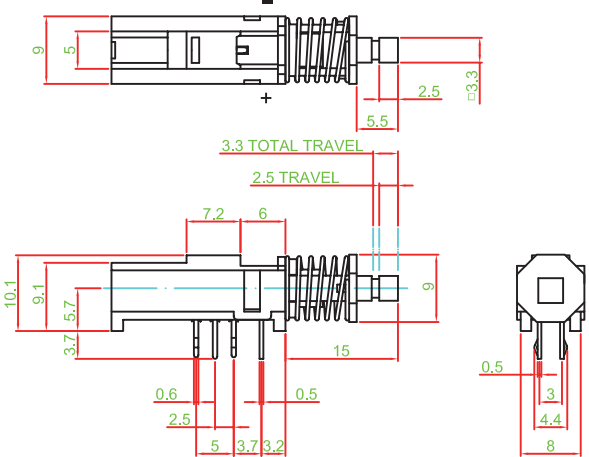
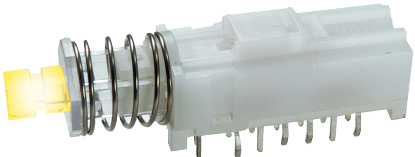
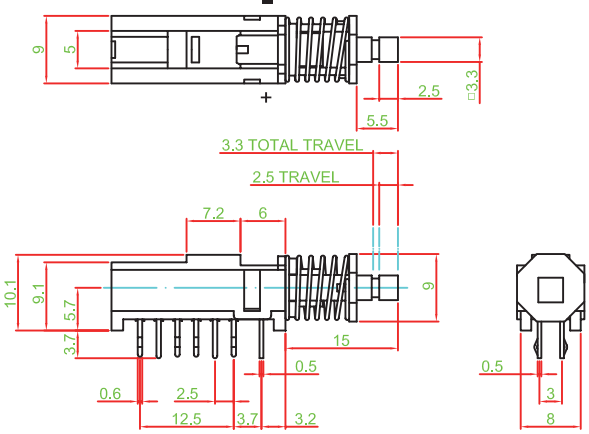
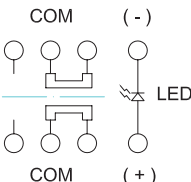
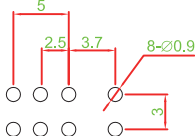
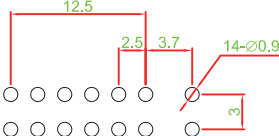
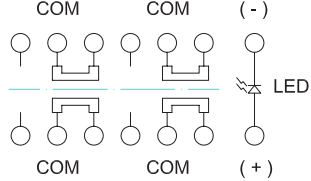
▶ DIMENSION		
<p style="text-align: center;">ML - 2L <input type="checkbox"/> <input type="checkbox"/></p> 		
<p style="text-align: center;">ML - 4N <input type="checkbox"/> <input type="checkbox"/></p> 		
▶ CIRCUIT	▶ P.C.B LAYOUT	
<p style="text-align: center;">ML - 2N <input type="checkbox"/> <input type="checkbox"/></p> 	<p style="text-align: center;">ML - 2N <input type="checkbox"/> <input type="checkbox"/></p> 	<p style="text-align: center;">ML - 4N <input type="checkbox"/> <input type="checkbox"/></p> 
<p style="text-align: center;">ML - 4N <input type="checkbox"/> <input type="checkbox"/></p> 	<p style="text-align: left; padding-left: 20px;">▶ UNIT WEIGHT</p> <ul style="list-style-type: none"> ■ COVER : POM ■ ACTUATOR : POM ■ BASE FRAME : PA + GF ■ TERMINAL : BRASS SILVER PLATING 	
▶ MATERIAL		
<ul style="list-style-type: none"> ■ ML - 2L <input type="checkbox"/> <input type="checkbox"/> : 2.45 ± 0.05 g / pc ■ ML - 4N <input type="checkbox"/> <input type="checkbox"/> : 2.5 ± 0.05 g / pc 		

